



## Air-Cooled Liquid Chillers with Integrated Hydronic Module

PRO-DIALOG PLUS



AQUASNAP



Carrier is participating in the Eurovent Certification Programme. Products are as listed in the Eurovent Directory of Certified Products.



# 30RA 017-033

## Nominal cooling capacity 18-32 kW

This new generation of liquid chillers features the latest technological innovations, incorporating scroll compressors and operating on the ecological refrigerant HFC-407C.

The 30RA chillers from Carrier have an integrated hydronic module, with pump and expansion tank, limiting the installation to simple operations like connection of the power supply and the water supply and return piping.

An auto-adaptive control system ensures intelligent control of the compressor start-up sequence.

### Features

- Refrigerant R-407C is a blend of R-32, R-125 and R-134a, ensures similar performances to those achieved with R-22 and offers an economical solution to environmental protection problems. It has no effect on the ozone layer and can be used as a replacement for R-22 in air conditioning applications with small and medium capacities.
- The components of these units are specifically designed for R-407C refrigerant, and all units have been submitted to the necessary laboratory tests to ensure perfect operation.
- The unit incorporates two axial fans with horizontal air discharge. The advanced design allows exceptionally low-noise operation.
- Compact unit dimensions facilitate installation of these units in restricted spaces.
- Prepainted steel panels.
- Removable panels for improved service and easier access to all components.
- The condenser coils are constructed of high-quality copper tube, expanded into pre-treated aluminium fins to offer high corrosion resistance in industrial and marine environments.
- The refrigerant-to-water heat exchangers are plate heat exchangers, ensuring excellent heat transfer at reduced dimensions and low weight. The plates are made of welded stainless steel. This heat exchanger type requires only minimum refrigerant quantities, compared with traditional heat exchangers.
- The scroll compressors run very quietly and vibration-free. They are known for their durability and reliability. The motor is fully cooled by suction gas and permits up to 12 starts per hour. The advanced concept of the scroll allows reverse rotation due to incorrect wiring, without impairing the operation of the compressor. These compressors are especially designed for operation with R-407C.
- The hydronic module is factory-installed. This eliminates the need to install the necessary components on site, making the unit more compact and easy to install.

### Water fill system:

- Spherical check valve
- Pressure reduction valve
- Safety valve

### Hydronic kit

- Flow switch
- Suction pressure gauge
- Expansion tank
- Spherical shutoff valve
- Filter
- Pressure pump
- Spherical control valve
- Discharge pressure gauge
- Automatic purge.

### PRO-DIALOG Plus control

PRO-DIALOG Plus is an advanced numeric control system that combines complex intelligence with great operating simplicity. PRO-DIALOG Plus constantly monitors all machine parameters and safety devices, and precisely manages the operation of compressor and fans for optimum energy efficiency. It also controls the operation of the water pump.

### A powerful control system

- The PID control algorithm with permanent compensation for the difference between entering and leaving water temperature anticipates load variations, and ensures intelligent leaving water temperature control.
- Reset of the leaving water temperature set point (according to the outdoor air temperature or the return water temperature).
- PRO-DIALOG Plus control is auto-adaptive for improved chiller protection. Compressor cycling is automatically adapted to the characteristics of the application according to the inertia of the water loop and prevents dangerous compressor short cycling.

### Clear and easy-to-use control system

- The operator interface is clear and user-friendly: LEDs and numeric displays ensure immediate verification of the unit operating data.
- A simple push of the button positioned on the synoptic chiller diagram gives you immediate display of the usual parameters: temperatures, pressures, set point, compressor run times etc.
- 10 menus offer direct access to all machine controls, including fault history, for rapid fault diagnosis.

### Extended communications capabilities

- PRO-DIALOG Plus offers a standard wired remote control with multiple functions for easy integration into any building management system: on/off control, cooling/heating mode selection, power demand limit or dual set point and a general alarm indication.
- The optional CCN Clockboard offers enhanced control possibilities:  
Time scheduling of the unit with up to eight sequences, cascade operation of two units, remote control by communication bus through its RS 485 serial port, time scheduling for low-speed fan operation.

## Options/accessories

	Option	Accessory
Unit without neutral	x	
220-3-50 power supply	x	
Unit without hydronic kit	x	
Water fill system	x	x
Coil protection grille	x	x

# Physical data

		<b>017</b>	<b>021</b>	<b>026</b>	<b>033</b>
<b>30RA</b>					
Net cooling capacity*	kW	17.70	21.60	25.80	31.70
Operating weight with hydronic module	kg	220	240	280	315
Operating weight without hydronic module	kg	200	220	250	285
Refrigerant charge R407C	kg	4.80	5.13	6.41	7.70
<b>Compressor</b>		One scroll compressor			
<b>Evaporator</b>		One plate heat exchanger			
Net water volume	l	1.50	1.88	2.16	2.82
Water connections (MPT gas)	in	1	1	1-1/4	1-1/4
Maximum water pressure	kPa	1000	1000	1000	1000
<b>Hydraulic circuit</b>		One single-speed, 230-1-50			
Pump					
Available pressure**	kPa	138	126	150	138
Water inlet connections	in	1-1/4	1-1/4	1-1/4	1-1/4
Water outlet connections	in	1	1	1-1/4	1-1/4
Expansion tank water volume	l	8	8	8	8
<b>Water fill system (option)</b>					
Inlet/outlet diameter	in	1/2	1/2	1/2	1/2
<b>Condenser</b>		One, copper tubes and pre-treated aluminium fins			
Tube diameter	in	3/8	3/8	3/8	3/8
No. of rows		2	3	2	3
Tubes/row		52	52	60	60
Fin spacing	mm	1.81	1.81	1.81	1.81
<b>Fan</b>		Two propeller fans			
Diameter	mm	500	500	610	610
No. of blades		5	5	5	5
Air flow	l/s	2450	2222	3278	3000
Fan speed	r/s	12.83	12.91	11.05	10.95

\* Based on an outdoor entering air temperature of 35°C, an evaporator entering water temperature of 12°C and an evaporator leaving water temperature of 7°C.

\*\* At nominal air flow

# Electrical data

		<b>017</b>	<b>021</b>	<b>026</b>	<b>033</b>
<b>30RA</b>					
Power supply	V-ph-Hz	400-3-50			
Voltage range	V	360-440			
Nominal power input	kW	6.43	8.57	9.56	12.39
Effective power input**	kW	6.54	8.72	9.75	12.60
Nominal current drawn*	A	10.75	15.50	18.80	24.55
Effective current drawn**	A	10.95	15.75	19.10	24.95
Max. power input	kW	7.87	10.80	12.23	14.95
Maximum current drawn***	A	13.50	20.00	22.50	28.00
Starting current	A	87	132	134	139
Pump power input	kW	0.65	0.68	0.89	0.93

\* Based on an outdoor entering air temperature of 35°C, an evaporator entering water temperature of 12°C and an evaporator leaving water temperature of 7°C.

\*\* Eurovent standard

\*\*\* Based on an outdoor entering air temperature of 46°C and an evaporator leaving water temperature of 10°C.

# Operating range - 30RA units

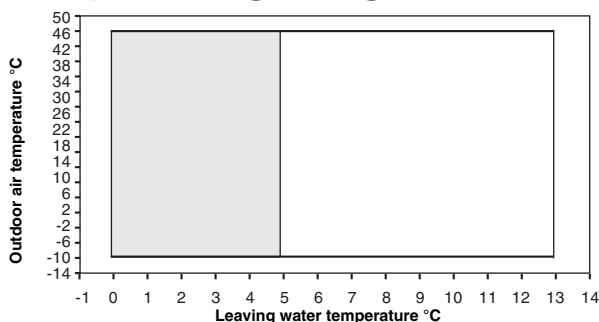

Operating range with anti-freeze solution and with special configuration of the Pro-dialog control system

### 30RA 026-033 standard unit

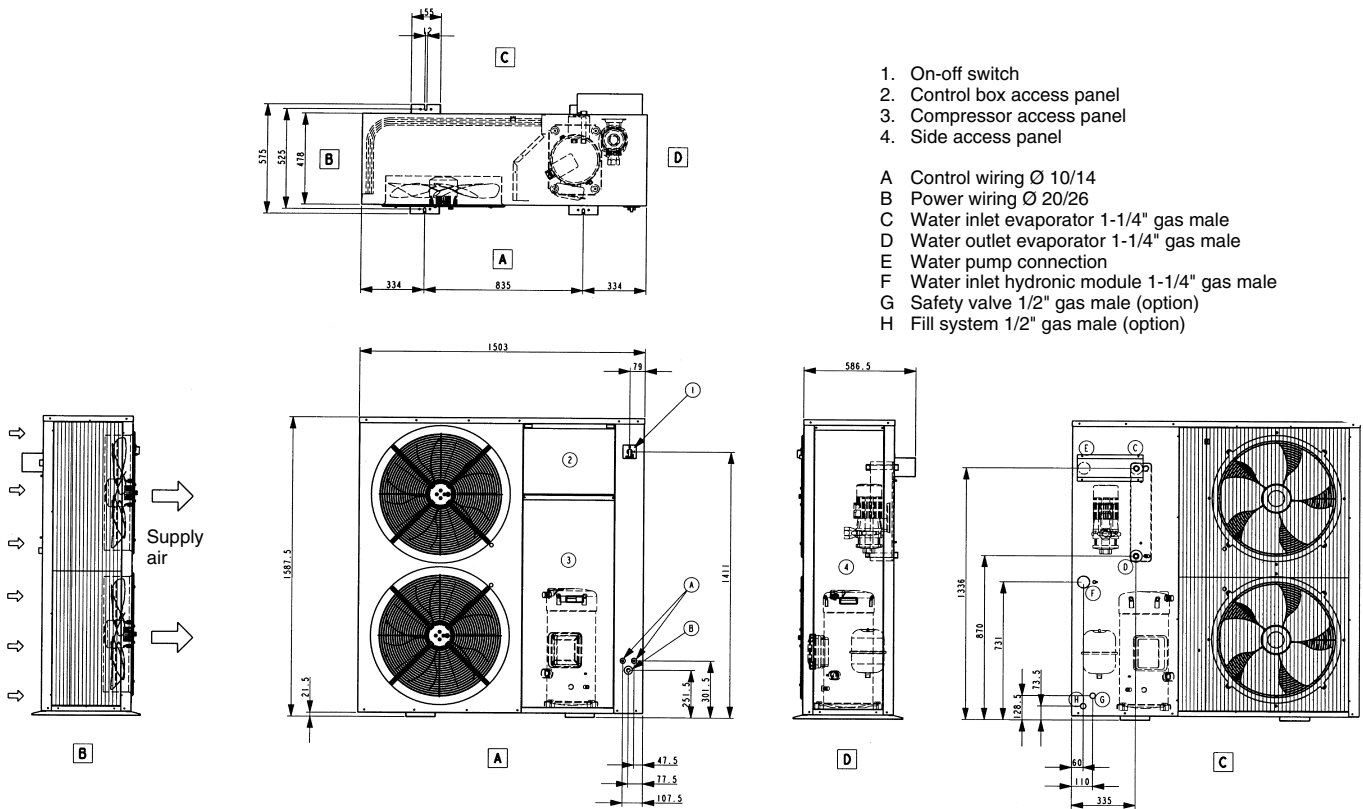

1. On-off switch
2. Control box access panel
3. Compressor access panel
4. Side access panel

- A Control wiring  $\varnothing$  10/14
- B Power wiring  $\varnothing$  20/26
- C Water inlet evaporator 1-1/4" gas male
- D Water outlet evaporator 1-1/4" gas male
- E Water pump connection
- F Water inlet hydronic module 1-1/4" gas male
- G Safety valve 1/2" gas male (option)
- H Fill system 1/2" gas male (option)

### 30RA 026-033 unit without hydronic kit

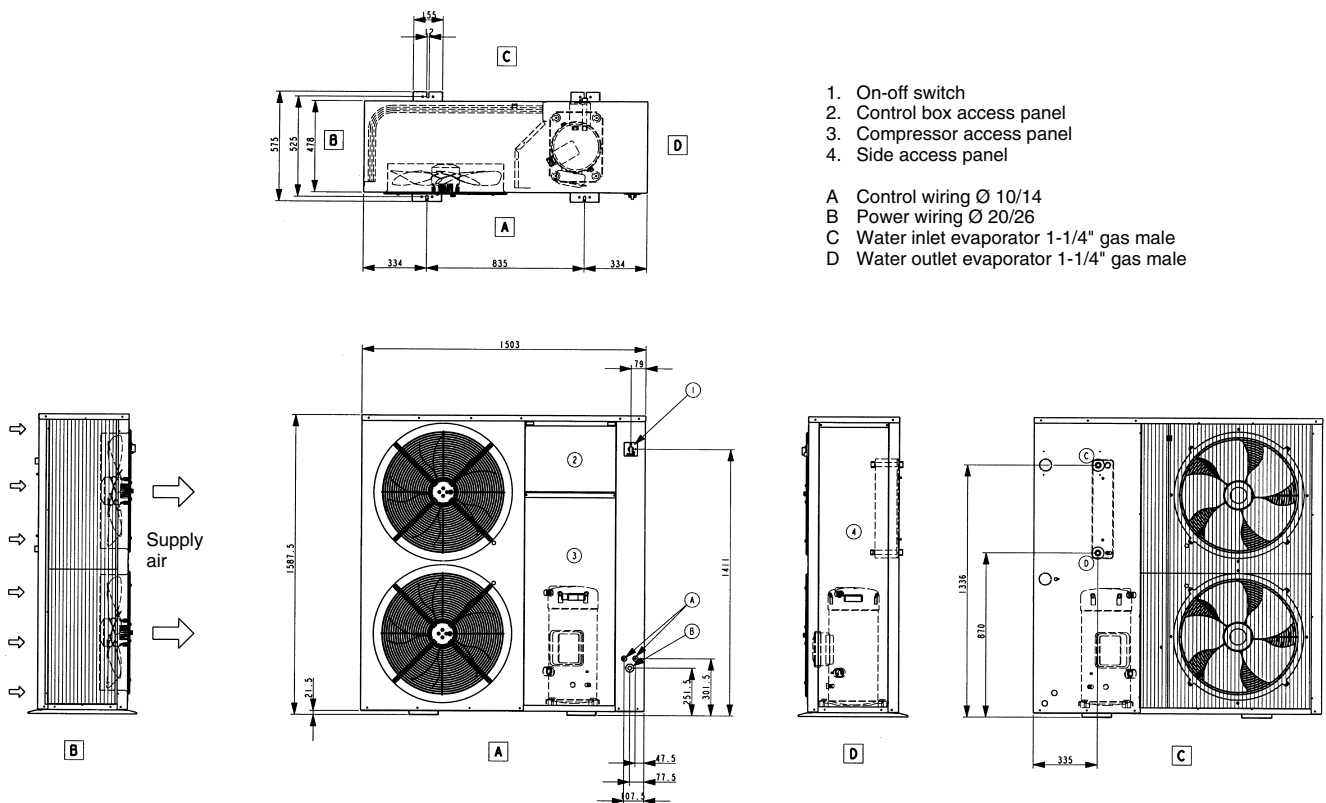

1. On-off switch
2. Control box access panel
3. Compressor access panel
4. Side access panel

- A Control wiring  $\varnothing$  10/14
- B Power wiring  $\varnothing$  20/26
- C Water inlet evaporator 1-1/4" gas male
- D Water outlet evaporator 1-1/4" gas male

# Clearances, mm

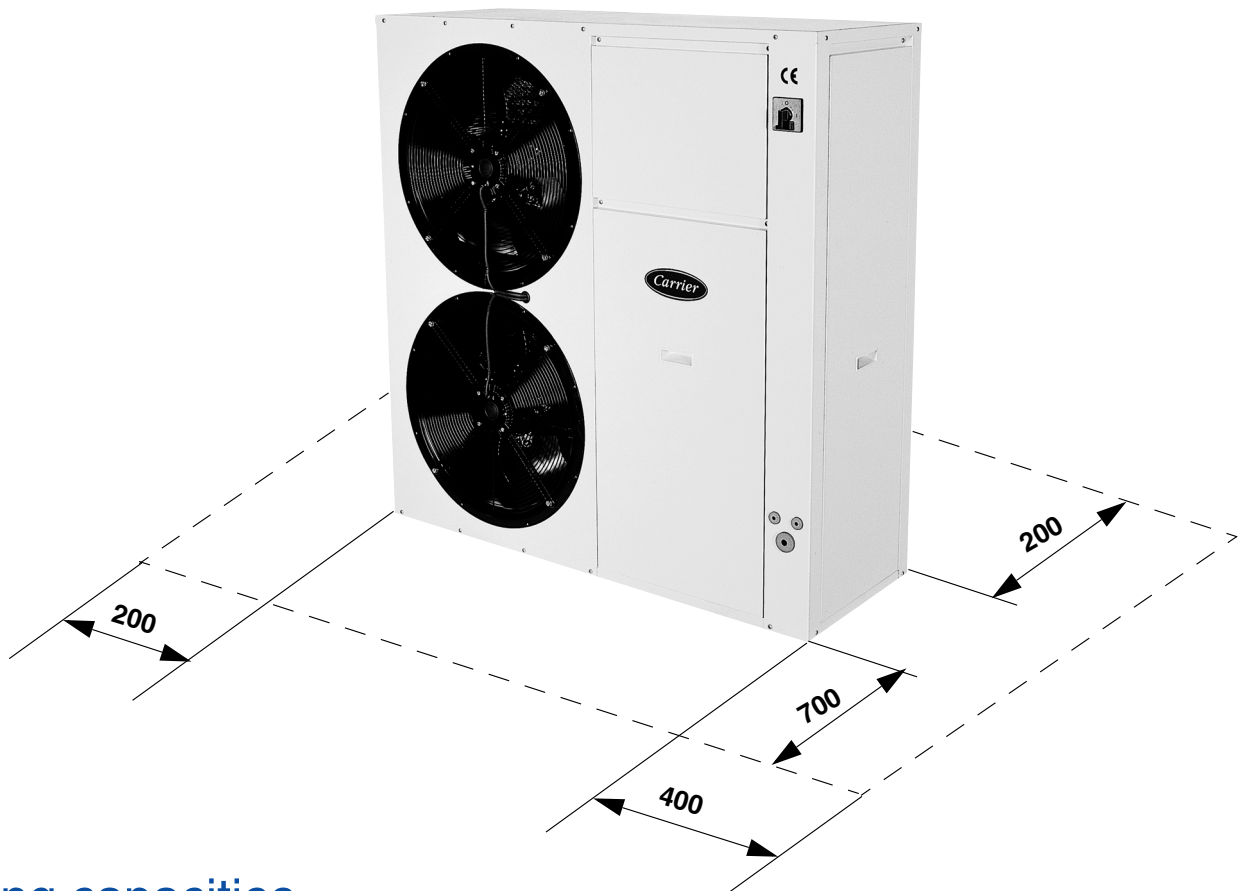

# Cooling capacities

30RA		Condenser entering air temperature, °C																								
		25					30					35					40					45				
LCWT	°C	CAP	COMP	UNIT	Cooler	Pres	CAP	COMP	UNIT	Cooler	Pres	CAP	COMP	UNIT	Cooler	Pres	CAP	COMP	UNIT	Cooler	Pres	CAP	COMP	UNIT	Cooler	Pres
		kW	kW	kW	l/s	kPa	kW	kW	kW	l/s	kPa	kW	kW	kW	l/s	kPa	kW	kW	kW	l/s	kPa	kW	kW	kW	l/s	kPa
017	5	18.50	4.65	5.33	0.88	134	17.70	5.17	5.87	0.84	138	16.60	5.74	6.45	0.79	144	15.40	6.36	7.08	0.73	149	14.00	7.03	7.79	0.66	156
021		22.40	6.18	7.16	1.08	121	21.40	6.80	7.81	1.03	127	20.20	7.48	8.54	0.97	134	18.90	8.21	9.32	0.91	141	17.50	8.99	10.15	0.84	147
026		27.00	6.94	8.02	1.29	144	25.70	7.71	8.81	1.23	150	24.30	8.56	9.69	1.16	157	22.60	9.50	10.71	1.08	165	20.60	10.51	11.71	0.99	172
033		34.80	9.44	10.46	1.66	125	32.40	10.29	11.26	1.55	136	29.80	11.27	12.25	1.43	145	27.30	12.35	13.35	1.30	155	24.70	13.53	14.64	1.18	164
017	6	19.00	4.66	5.34	0.90	131	18.20	5.19	5.88	0.86	135	17.10	5.76	6.46	0.81	140	15.90	6.39	7.10	0.76	147	14.50	7.06	7.81	0.69	154
021		23.10	6.25	7.23	1.11	117	22.10	6.88	7.89	1.06	124	20.90	7.55	8.61	1.00	130	19.60	8.29	9.39	0.94	137	18.10	9.07	10.25	0.87	144
026		27.80	6.96	8.03	1.33	140	26.60	7.74	8.83	1.27	146	25.00	8.60	9.73	1.20	153	23.30	9.54	10.71	1.12	162	21.30	10.61	11.81	1.02	170
033		35.50	9.61	10.56	1.70	122	33.10	10.39	11.45	1.58	132	30.80	11.37	12.35	1.47	142	28.40	12.45	13.45	1.36	151	25.90	13.63	14.74	1.24	160
017	7	19.50	4.67	5.35	0.92	128	18.70	5.20	5.89	0.89	133	17.70	5.8	6.5	0.84	138	16.40	6.40	7.12	0.78	144	15.00	7.09	7.83	0.71	151
021		23.80	6.31	7.31	1.14	112	22.80	6.94	7.96	1.09	120	21.60	7.6	8.7	1.03	126	20.20	8.35	9.47	0.97	133	18.80	9.14	10.25	0.90	141
026		28.60	6.98	8.05	1.37	136	27.40	7.76	8.86	1.31	142	25.80	8.6	9.8	1.23	150	24.00	9.59	10.71	1.15	158	21.90	10.61	11.81	1.05	167
033		36.20	9.76	10.76	1.73	118	33.90	10.59	11.55	1.62	128	31.70	11.5	12.6	1.51	138	29.40	12.55	13.55	1.41	147	27.20	13.72	14.84	1.30	156
017	8	20.00	4.68	5.36	0.95	125	19.20	5.22	5.90	0.91	130	18.20	5.80	6.49	0.86	135	17.00	6.43	7.14	0.81	142	15.60	7.12	7.85	0.74	149
021		24.50	6.38	7.38	1.18	108	23.40	7.01	8.04	1.12	115	22.20	7.70	8.76	1.07	122	20.90	8.43	9.54	1.00	130	19.50	9.22	10.35	0.94	138
026		29.50	6.99	8.07	1.41	131	28.20	7.79	8.89	1.35	138	26.60	8.67	9.80	1.27	146	24.70	9.64	10.81	1.18	155	22.60	10.70	11.91	1.08	165
033		36.80	9.90	10.96	1.76	115	34.70	10.69	11.75	1.66	125	32.60	11.67	12.65	1.56	134	30.50	12.65	13.75	1.46	143	28.40	13.82	14.94	1.36	151
017	10	20.90	4.70	5.38	1.00	119	20.20	5.25	5.93	0.96	124	19.20	5.84	6.53	0.91	130	18.00	6.48	7.18	0.86	136	16.60	7.18	7.90	0.79	144
021		25.90	6.51	7.54	1.25	99	24.80	7.15	8.19	1.19	106	23.60	7.84	8.92	1.13	115	22.30	8.58	9.70	1.07	122	20.80	9.37	10.55	1.00	131
026		31.20	7.02	8.12	1.49	122	29.80	7.84	8.95	1.42	130	28.10	8.75	9.87	1.34	139	26.20	9.73	10.91	1.25	148	24.00	10.80	12.01	1.15	158
033		38.10	10.29	11.35	1.82	109	36.30	10.98	12.05	1.74	118	34.50	11.86	12.95	1.65	126	32.60	12.84	13.94	1.56	134	30.80	14.02	15.14	1.47	142

### Legend

- LWT** Leaving water temperature
- CAP kW** Net cooling capacity = gross cooling capacity plus the capacity corresponding to the available pressure (flow x pressure/0.3)
- COMP kW** Compressor power input
- UNIT kW** Unit power input (compressor, fans, control circuit and pumps) minus the power corresponding to the available pressure (flow x pressure/0.3)
- Cooler l/s** Water heat exchanger water flow rate
- Pres kPa** Available pressure at the unit outlet (unit with single-pump hydronic module)

### Full load correction factors for Eurovent laboratory test:

- Net cooling capacity 1.00
- Energy efficiency ratio 1.00

### Application data:

- Refrigerant: R-407C
- Evaporator temperature drop: 5 K
- Evaporator fluid: chilled water
- Fouling factor: 0.000044 m<sup>2</sup> K/W

### The published performances are in accordance with EUROVENT tolerances:

- 5% for heating and cooling capacities
- +5% for power input
- +15% for the pressure drop

Capacity based on standard EUROVENT conditions



Order No. 13003-20, 06.02. Supersedes order No.: 13003-20, 11.01.  
Manufacturer reserves the right to change any product specifications without notice.

Manufactured by: Carrier, Villasanta, Italy.  
Printed on Totally Chlorine Free Paper.  
Printed in the Netherlands.